

AIR FILTRATION SYSTEMS



# FABRIC FILTER FLUE GAS TREATMENT CASE STORIES



**APPLICATION**

RDF combustion / gassification

**SECTOR**

Waste to Energy

**NOM. AIR FLOW**

330.000 m<sup>3</sup>/h

**DETAILS**

PULCO AIR BAGHOUSE, thermally insulated, installed for the flue gas treatment generated from the combustion process of municipal waste.

It has been designed in modules to simplify overseas shipment, to minimize assembly operations onsite and to do offline and online emergency maintenance procedure. The supply is completed with the reaction tower and the sorbent injection system in order to reduce the toxic emissions.

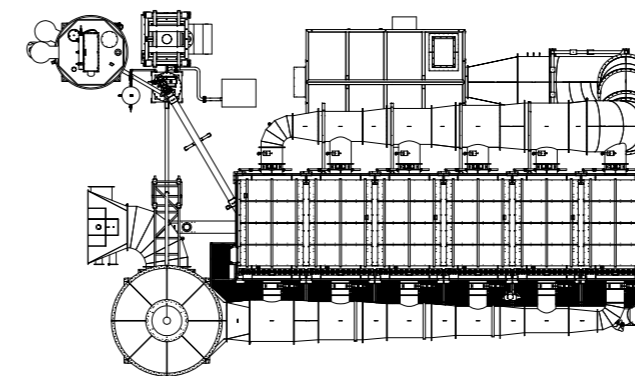
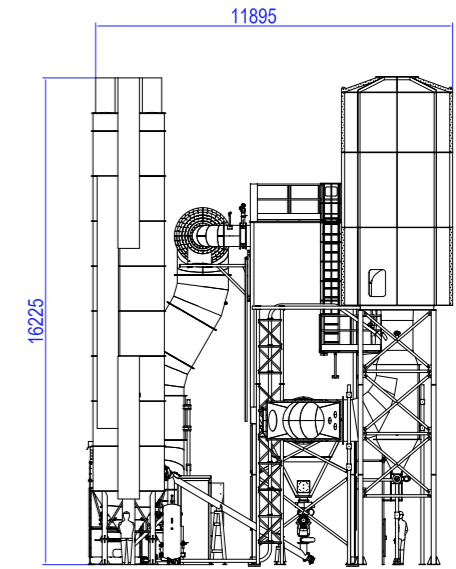
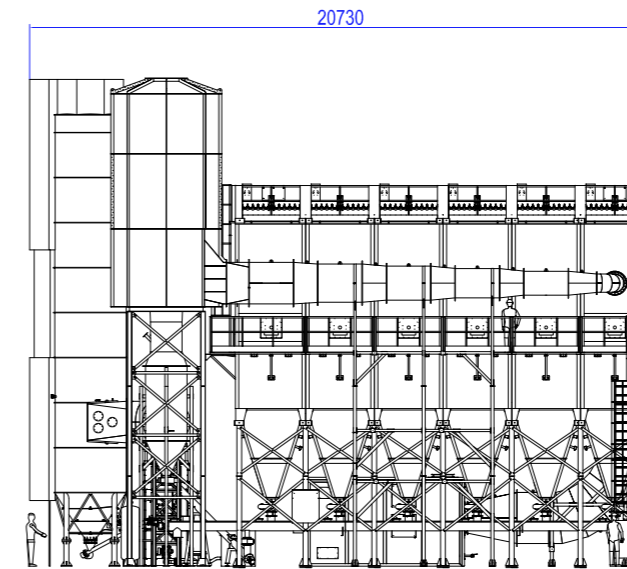

#### APPLICATION

RDF combustion / gassification

#### SECTOR

Waste to Energy

#### NOM. AIR FLOW

220.000 m<sup>3</sup>/h

#### DETAILS

PULCO AIR BAGHOUSE, thermally insulated, installed for the flue gas treatment generated from the combustion / gassification process of RDF.

It has been designed in modules to simplify overseas shipment, to minimize assembly operations onsite and to do offline and online emergency maintenance procedures.

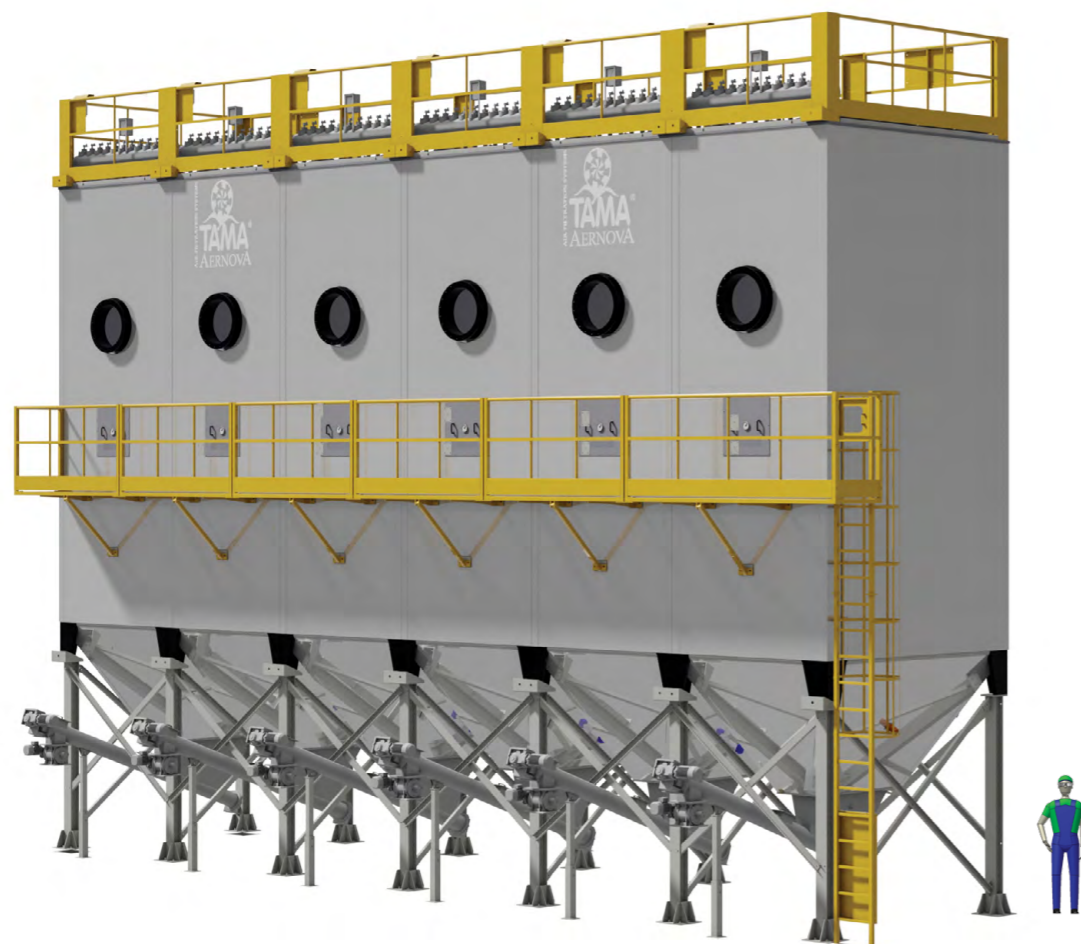
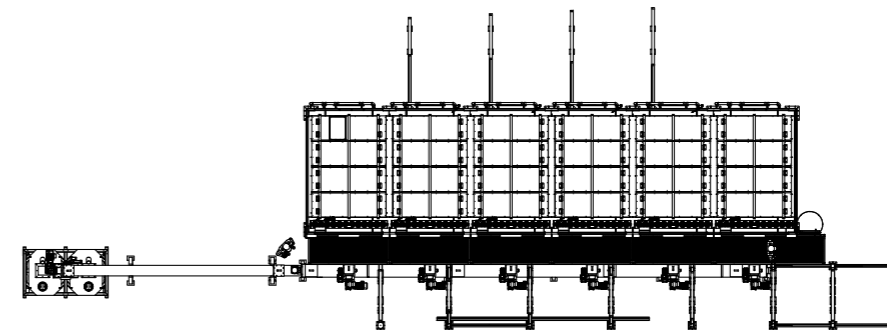
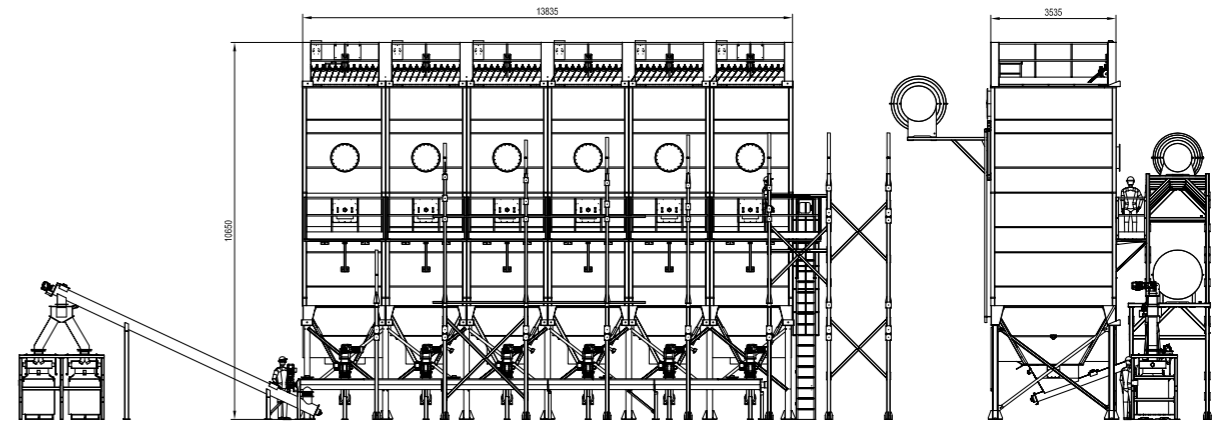

**APPLICATION**

Municipal waste combustion

**SECTOR**

Waste to Energy

**NOM. AIR FLOW**

63.000 m<sup>3</sup>/h

**DETAILS**

PULCO AIR BAGHOUSE, thermally insulated, installed for the flue gas treatment generated from the combustion process of municipal waste.

It has been designed in modules to simplify overseas shipment and to minimize assembly operations onsite. The supply is completed with the reaction tower and the sorbent injection system in order to reduce the toxic emissions.

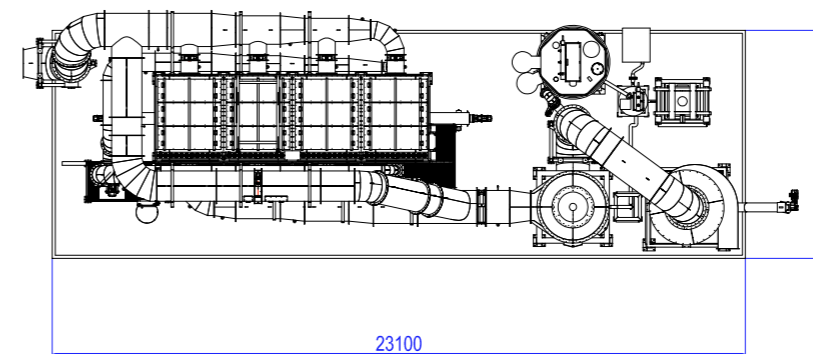
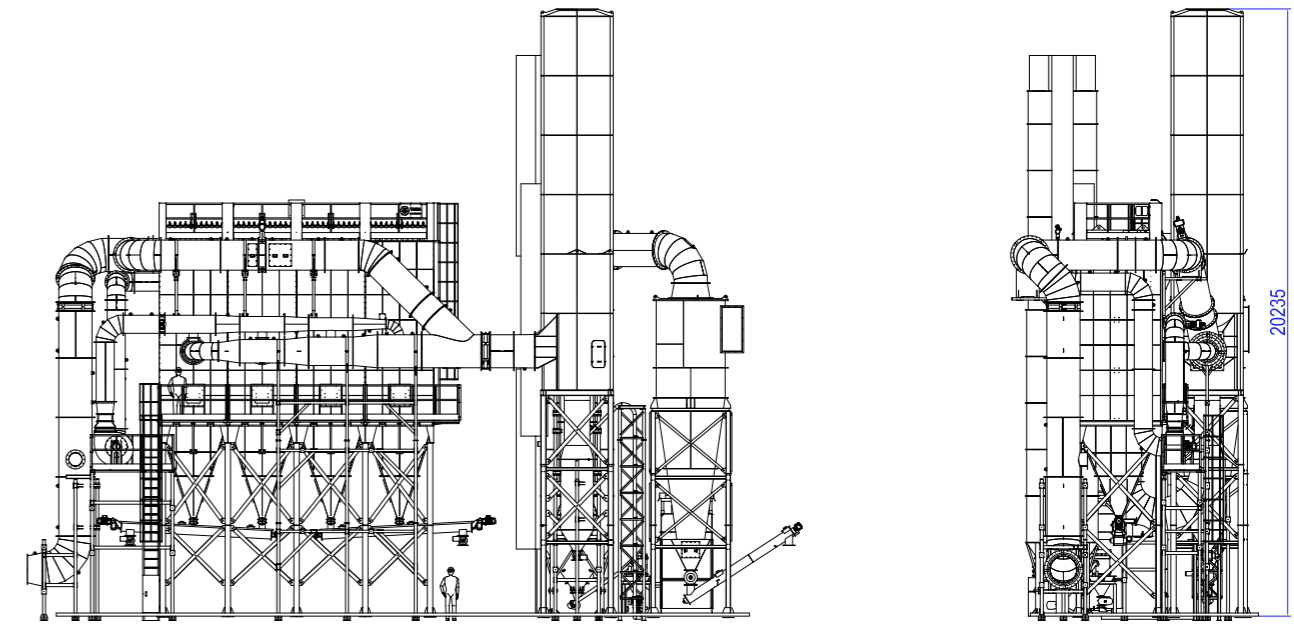
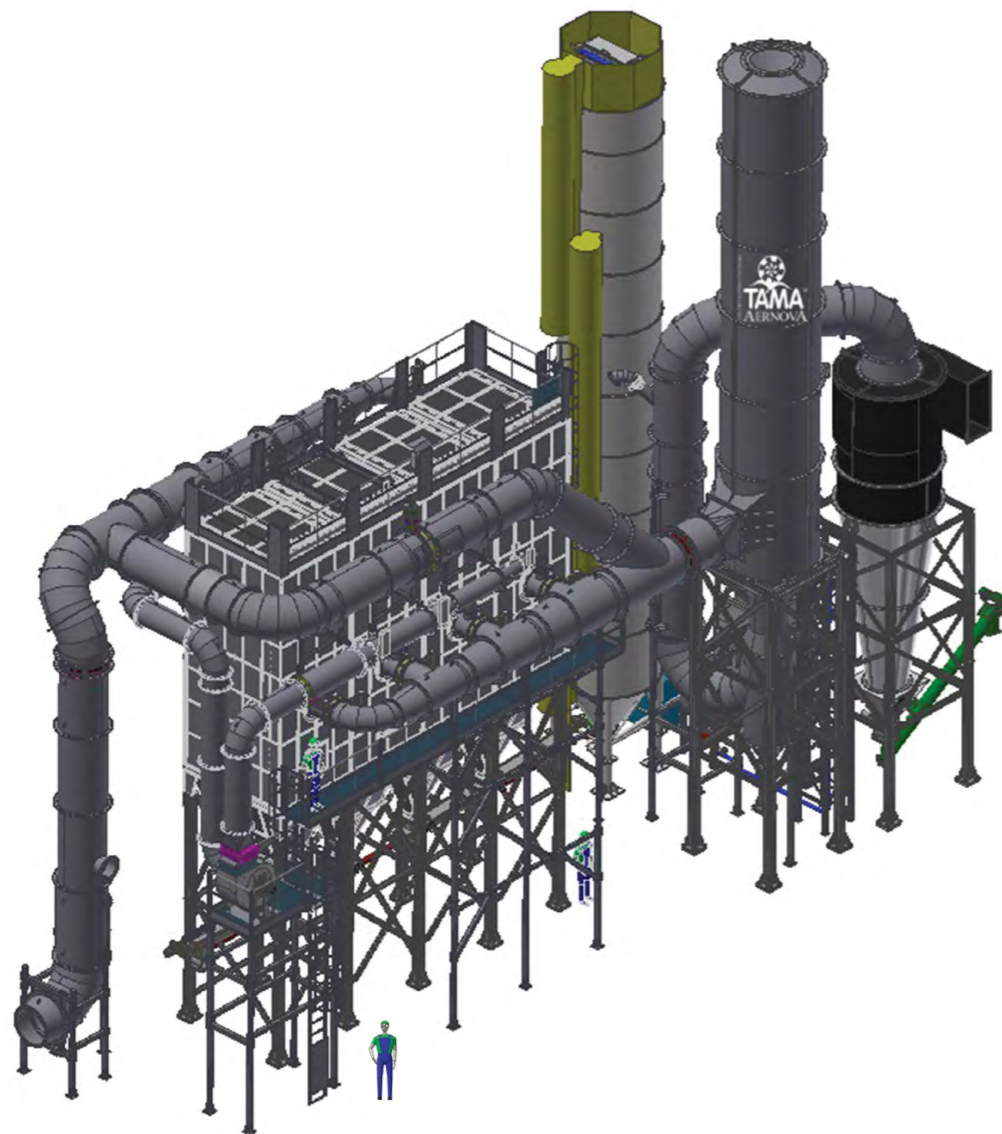

**APPLICATION**

Epoxy Foam grinding

**SECTOR**

Chemical

**NOM. AIR FLOW**

60.000 m<sup>3</sup>/h

**DETAILS**

PULCO AIR BAGHOUSE installed to filter air from dust and fumes generated during processing of epoxy foam blocks. The dust collector system is installed to fulfill ATEX regulations with several different safety devices and a special anticorrosion coating.

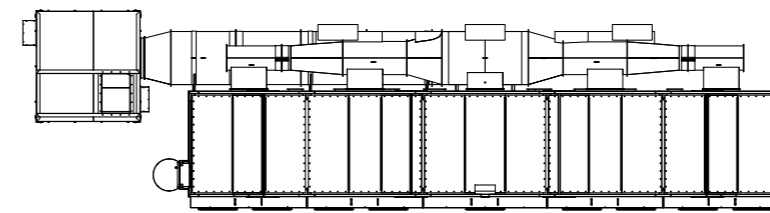
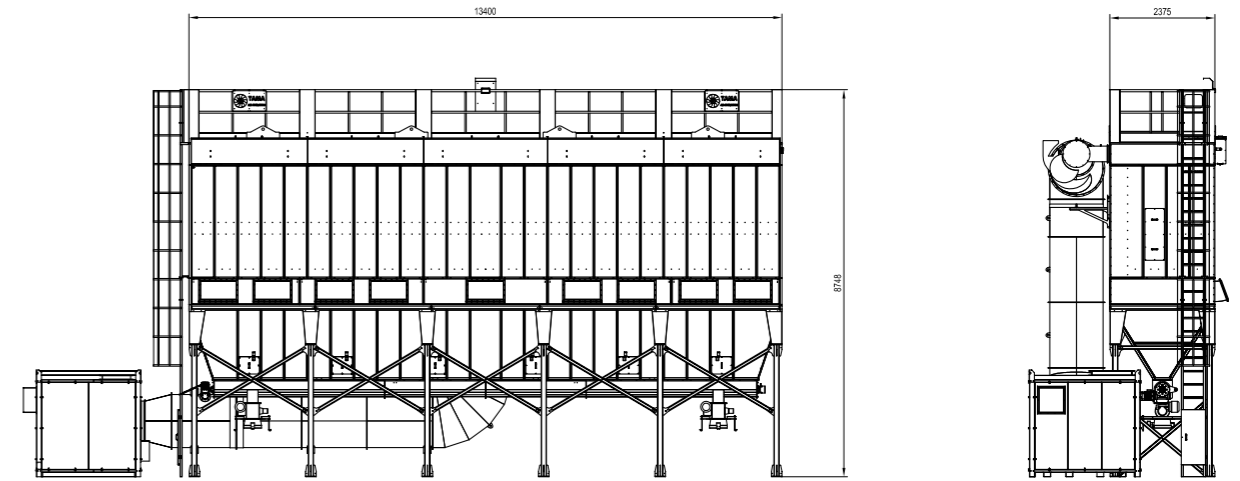

**APPLICATION**

Asphalt production

**SECTOR**

Asphalt / Cement

**NOM. AIR FLOW**

130.000 m<sup>3</sup>/h

**DETAILS**

PULCO AIR BAGHOUSE installed to filter air from dust and fumes generated during a process of asphalt production. The filter is built with elliptical baghouses in order to reduce its dimensions but able to keep high filtering surfaces. The filter is suitable for high temperatures and thermally insulated.

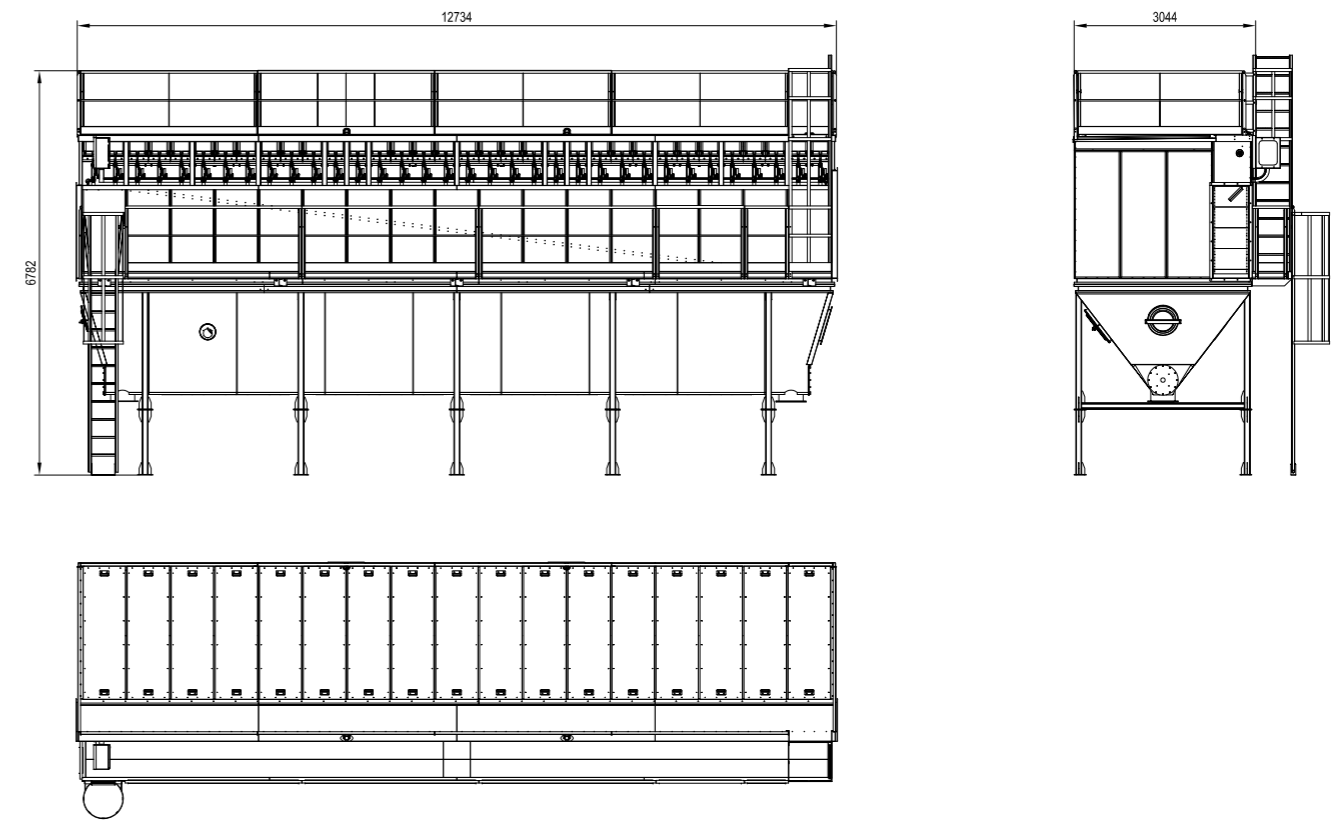

**APPLICATION**

Waste sorting

**SECTOR**

Recycling

**NOM. AIR FLOW**

110.000 m<sup>3</sup>/h

**DETAILS**

PULCO AIR BAGHOUSE installed to filter air from dust and fumes generated from the transport, storage and separation of waste. Conveniently designed for the air volumes and the low pressure areas originated by the plant, supplied with fan, connection ducting and chimney.

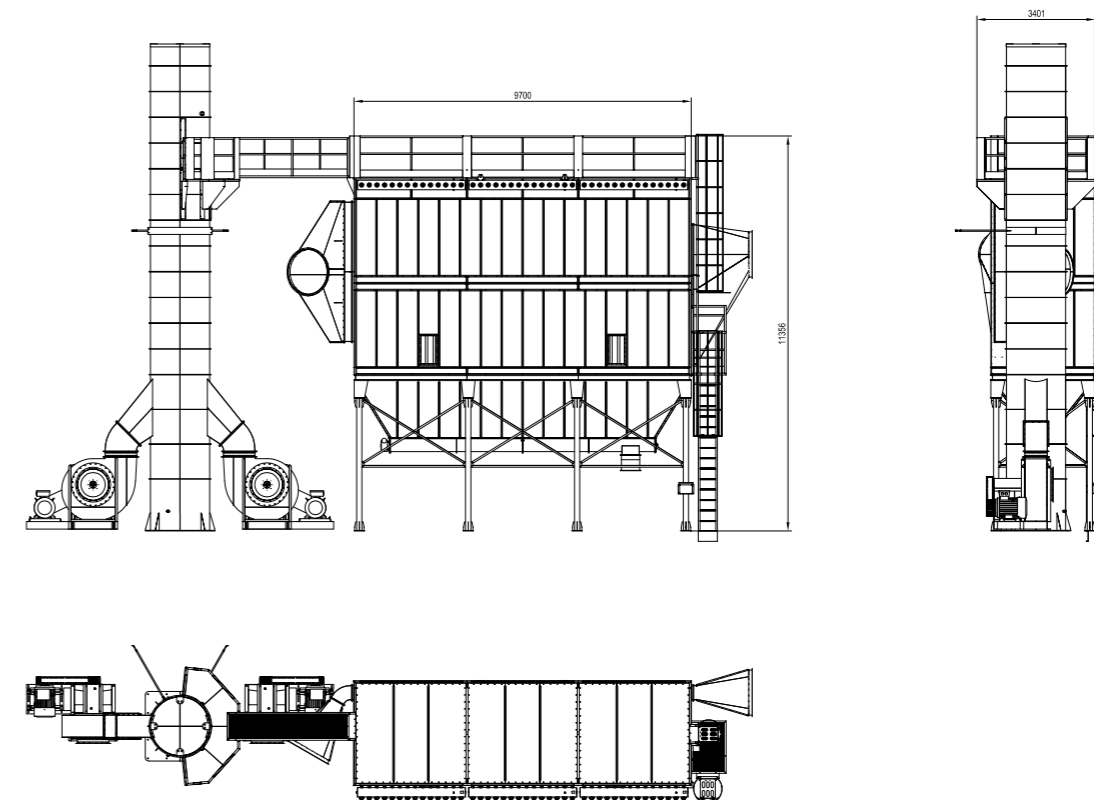

**APPLICATION**

Polypropylene production

**SECTOR**

Oil & Gas

**NOM. AIR FLOW**

73.000 m<sup>3</sup>/h

**DETAILS**

PULCO AIR BAGHOUSE installed to filter air from dust and fumes generated during a process of polypropylene production in a petrochemical refinery. Designed to filter potentially explosive dust, Atex 22 certified, with venting panels and rotary valves for the continuously unload.

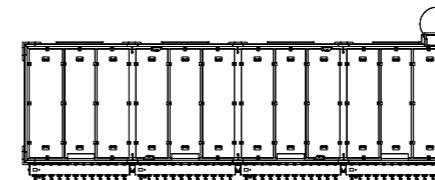
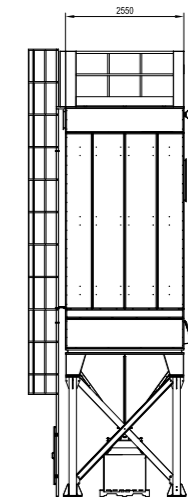
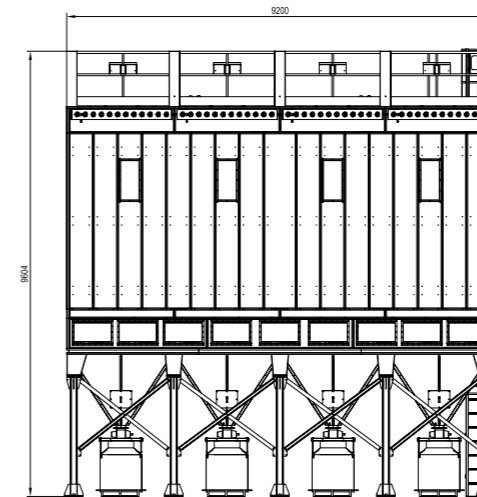



**APPLICATION**

Fluidized- bed Granulator

**SECTOR**

Chemical

**NOM. AIR FLOW**

60.000 m<sup>3</sup>/h

**DETAILS**

PULCO AIR BAGHOUSE completely made of stainless steel INOX 316 L, thermally insulated with rockwool and stainless steel panels, equipped with hopper conveniently coupled with the fluid bed granulator and internally installed at the height of 10 m on a certified structure according to the EN-1090. The electronic management system monitors and precisely manages the perfect balance of all the components applied, guaranteeing the optimum granulation process from the injection of the slurry to the unloading of the granule.

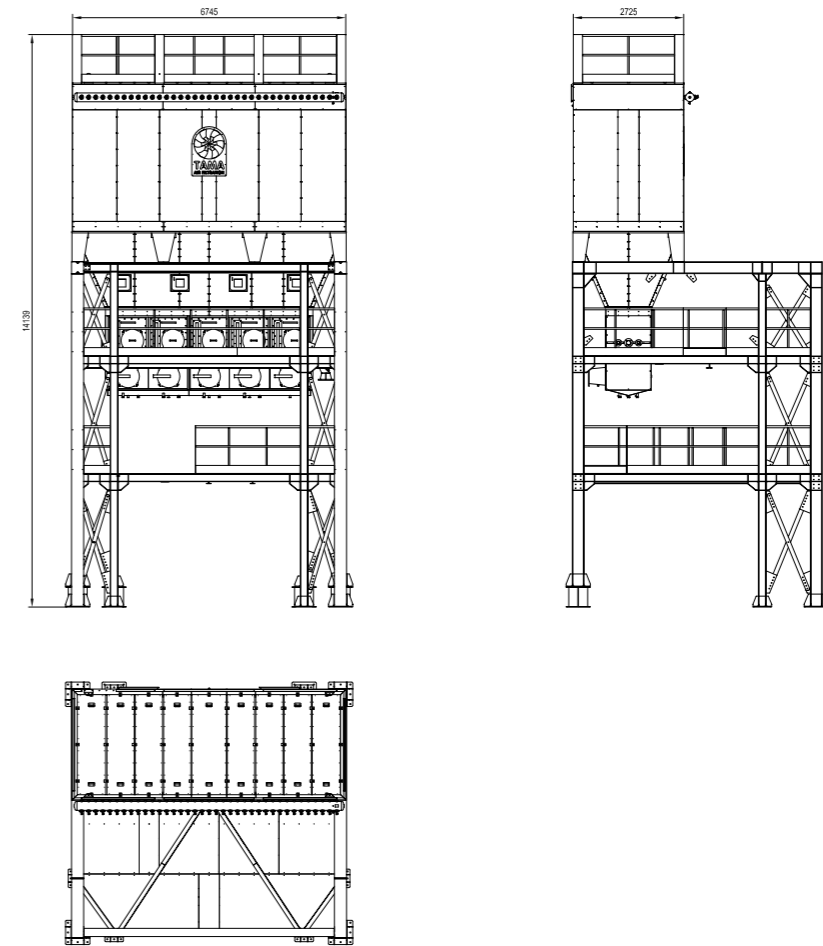

**APPLICATION**

Australian coal combustion

**SECTOR**

Power

**NOM. AIR FLOW**

112.000 m<sup>3</sup>/h

**DETAILS**

PULCO AIR BAGHOUSE installed for the flue gas treatment generated by the combustion and the processing of Australian coal. The filter has been designed to optimize the filtering capacity in order to reduce the overall dimensions. All the component are suitable for high temperatures.

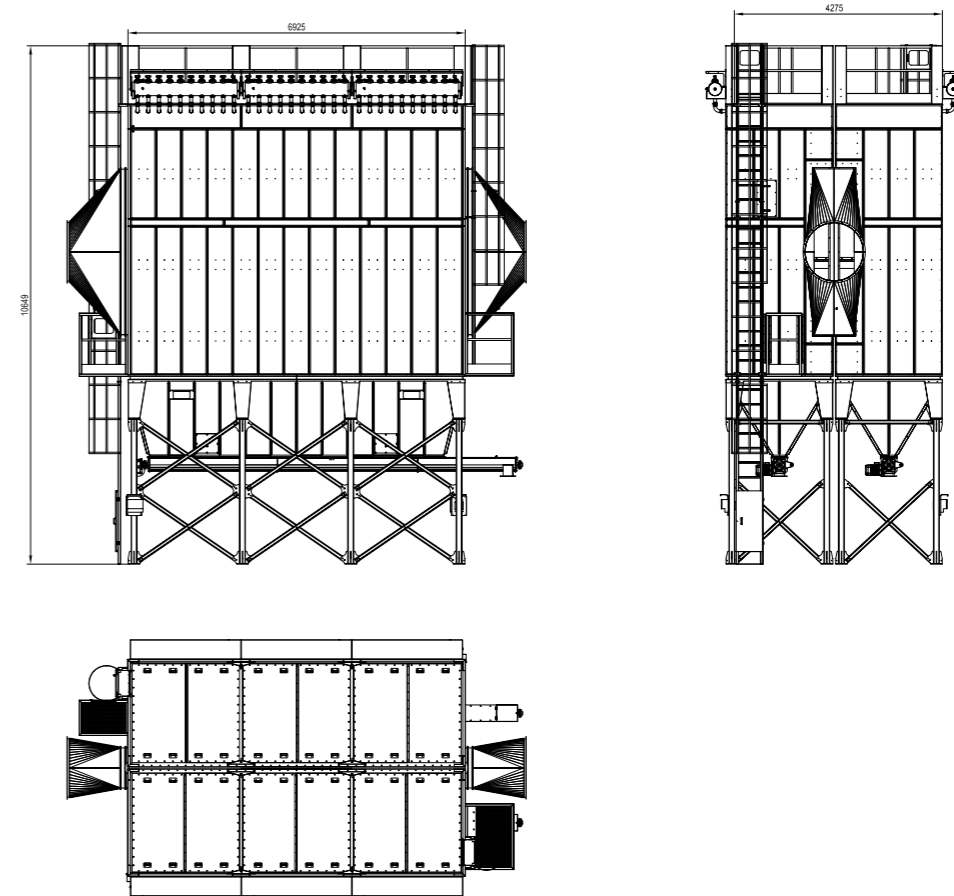
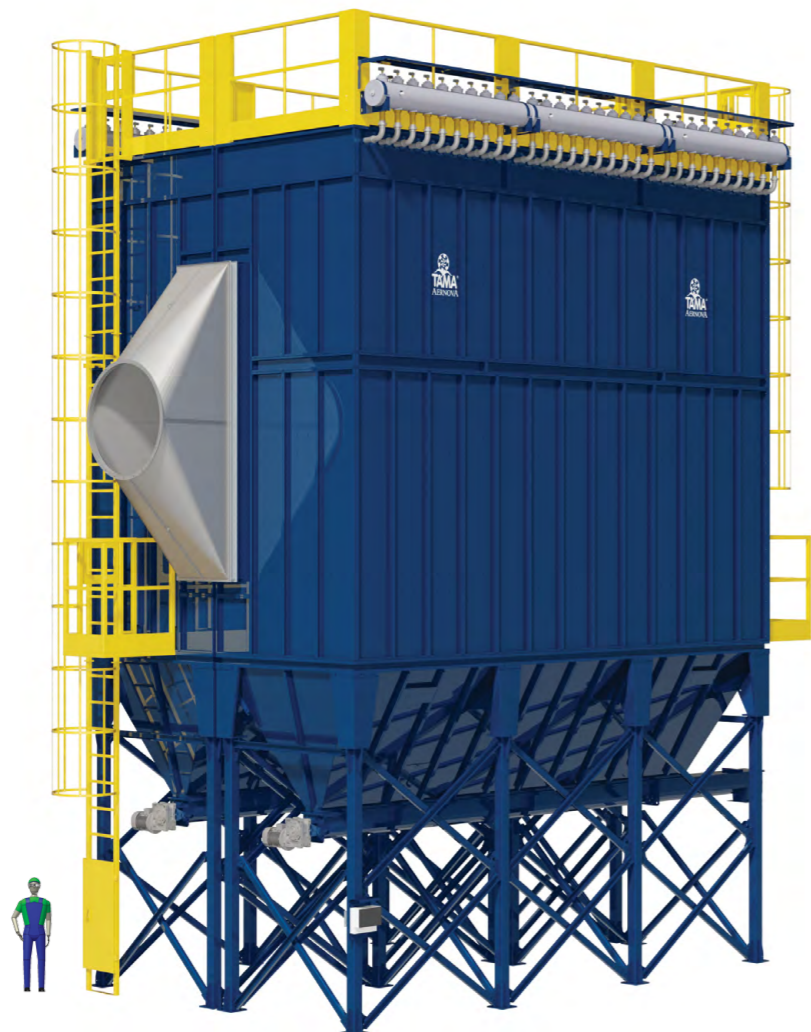

**APPLICATION**

Cast iron melt processing

**SECTOR**

Foundry

**NOM. AIR FLOW**

110.000 m<sup>3</sup>/h

**DETAILS**

PULCO AIR BAGHOUSE installed for the flue gas treatment generated during cast iron melt processing. The Filter has been designed to optimize the air distribution on the filtering surface. The ash discharging system is capable to work in continuous.

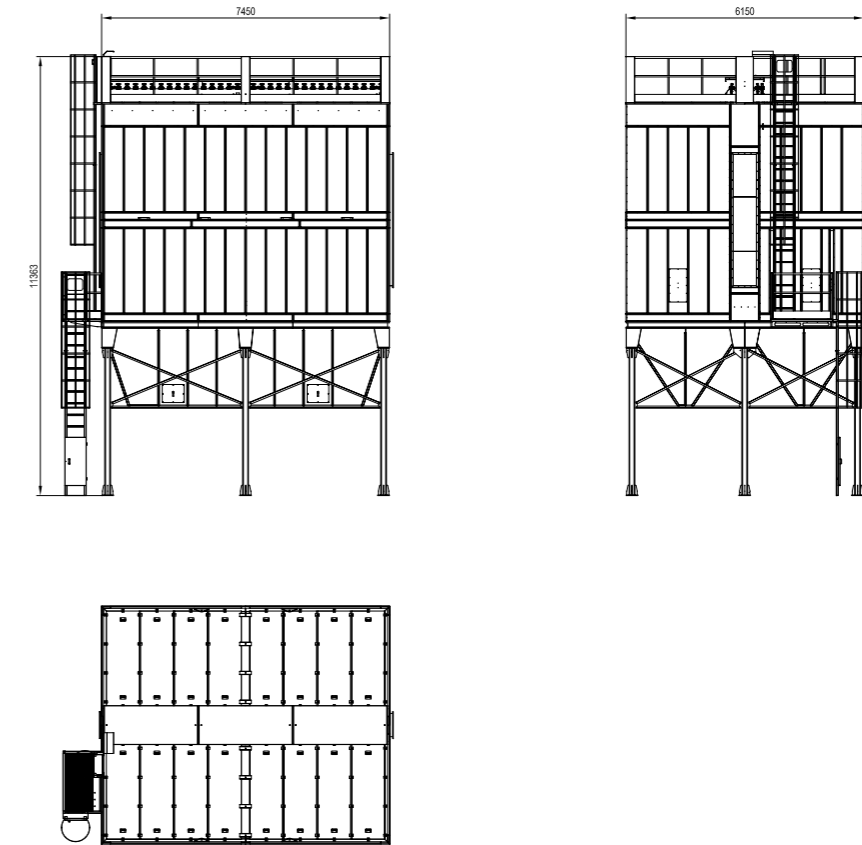



TAMA was born in 1985 in a small workshop in the heart of Trentino, Italy.

In 2002, TAMA France opened in Lyon, while in 2006 TAMA Iberica started operating in Barcelona, to complement the historic Italian headquarters and ensure a strong presence abroad, at European level.

In 2013 we founded TAMA Brasil, in Flores da Cunha, in Rio Grande do Sul State, an opportunity TAMA grasped in order to ensure its presence even in the Latin American market, an area that is experiencing now a strong growth and great development.

In 2016 we opened a new branch in Germany: Tama Entstaubungstechnik GmbH, in Essen, to better fullfil the request coming from a strong market.

In July 2016 was founded TAMA AERNOVA S.r.l. (now S.p.A.) thanks to the transfer of branch of business TAMA S.p.A. and AERNOVA ENGINEERING S.r.l., two companes with a thirty years experience in the field of air filtration. Today many companies in the world rely on our suction systems.

Wherever you are, we can assist you from both the commercial and after-sales point of view, through:

- CONSULTING AND DESIGN
- UNSCHEDULED MAINTENANCE OPERATIONS
- SUPPLY OF SPARE PARTS
- ASSISTANCE FOR THE UPDATE ON REGULATIONS AND THE ADAPTATION OF SYSTEMS

**MAXIMUM SAFETY IN CASE OF FLAMMABLE POWDERS ACCORDING TO THE REQUIREMENTS OF THE ATEX DIRECTIVE**



In the area of environmental safety we are able to offer you specific design advice in the cases of potentially explosive combustibile powders, combining your manufacturing needs with the precisions set out by the ATEX.

**FLUID DYNAMICS AND STRUCTURAL ANALISYS**

Thanks to our experience in the field of filtration, we are able to accept new challenges that allow us to offer our customers high-performance products.



Environmental Certification  
UNI EN ISO 14001:2004



Quality Certification  
UNI EN ISO 9001:2008



Health & Safety Certification  
BS OHSAS 18001:2007

# TAMA AERNOVA

ITALY, FRANCE, SPAIN, BRAZIL, GERMANY: FIVE HEADQUARTERS FOR ONE GLOBAL PARTNER

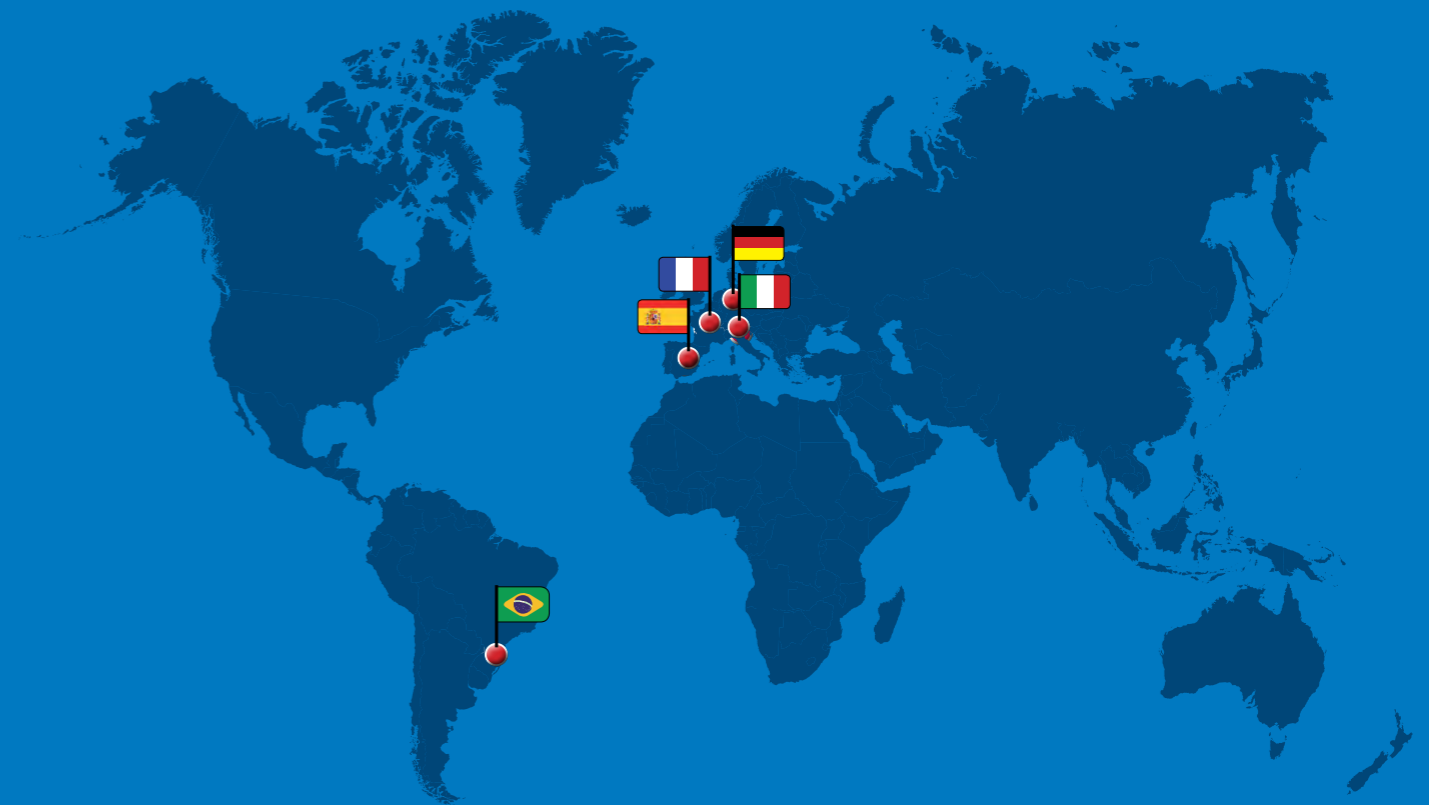



## ITALY

TAMA AERNOVA S.P.A.

Via dell'Industria, 11 Frazione Mollaro | 38012 Predaia - TN | Italy | tel. +39 0463 46 17 00

Via Roma, 120/122 | 10060 Roletto - TO | Italy

## FRANCE

TAMA FRANCE SARL

75, Rue de Malacombe | 38070 Saint Quentin Fallavier | France | tél. +33 04 74 82 42 20

## SPAIN

TAMA IBÉRICA s.l.

Avda. Santa Eulalia, 227 | 08223 Terrassa - Barcelona | España | tel. +34 93 72 38 628

## BRASIL

TAMA BRASIL ASPIRAÇÃO INDUSTRIAL LTDA

Doutor Fredi Corrales Marin, 46 | Cinquentenário (Lot Sanvitto II) | RS | CEP 95012-627 | Brasil | tel. +55 54 30 67 49 03

## GERMANY

TAMA ENTSTAUBUNGSTECHNIK GMBH

Haberstrasse 42 | 42551 Velbert | Germany | tel. +49 2051 9150735

[INFO@TAMAAERNOVA.COM](mailto:INFO@TAMAAERNOVA.COM) | [TAMAAERNOVA.COM](http://TAMAAERNOVA.COM)

